

Global Excellent
Warm Pack Equipment Supplier

全球优秀暖包设备供应商



Scan QR code
Enter the official website
扫描二维码进入官网

JACHIN
佳诚机械



Leading the industry into the future
**Smart Innovation
for Healthcare**

引领行业未来 智造守护健康

JACHIN 温州佳诚机械有限公司
佳诚机械 WENZHOU JIACHENG MACHINERY CO.,LTD.

① No.951, Xinghe Road, Wanquan Town, Pingyang County,
Wenzhou City, Zhejiang Province, China
浙江省温州市平阳县万全镇兴和路951号

② www.jiachengjixie.com
www.jiachengjixie.com/?_l=en
③ 0577-58128588 / 0577-58128555
(国内销售 Domestic Sales)

④ 15888782884 / 17706665780
⑤ +86-15382581100 / +86-17706665780
⑥ +86-15382581100 / +86-17706665780
(外贸 Foreign Trade)

Global Excellent
Warm Pack
Equipment Supplier

全球优秀暖包设备供应商

Shaping Industries

One Package at a Time

塑行业未来 创包装新章



Wenzhou Jiacheng Machinery Co., Ltd. is located in China's coastal city of Wenzhou Pingyang, is a technical strength and economic strength of science and technology-based enterprises. Now the enterprise covers an area of 7613 square meters, workshop construction area of 12647.74 square meters, building construction area of 2466.59 square meters.

Wenzhou Jiacheng Machinery Co., Ltd. (formerly "Ruian City Jiacheng Machinery Factory") was founded in October 2005, in September 2014 was officially renamed "Wenzhou Jiacheng Machinery Co. Ltd." It is a technology-based enterprise specializing in the production of Cup Lid Making Machine, Warmer Pad Making Machine, Moxibustion Patch Packaging Machine, Neck Therapy Patch Packaging Machine, Four Side Seal Packaging Machine, Steam Eye Mask Packaging Machine. We have certain technical force and advanced production technology; modernized scientific management system and perfect service system, with an elite team with youthful vitality

Since the establishment of the company, always adhere to the "integrity-based, quality first, excellent service, development and learning, innovation" spirit of enterprise. In the spirit of "people-oriented technology, customer-oriented service" development concept, in recent years the company site to implement 6S management, and constantly improve the working environment to enhance the level of integrated management, and constantly create a good working atmosphere to build a culture of core value system, and constantly enhance the overall capacity of the enterprise, adhering to the sincerity of the road to win the best to open up the market, but also to become more and more enterprises can be relied on. We are willing to become a reliable long-term partner for more enterprises!



温州佳诚机械有限公司坐落在中国海滨城市温州平阳，是一家技术力量和经济实力科技型企。现企业占地面积7613平方、车间建筑面积12647.74平方、综合楼建筑面积2466.59平方。

温州佳诚机械有限公司（原“瑞安市佳诚机械厂”）成立于2005年10月，在2014年9月正式更名为“温州佳诚机械有限公司”，传承20年的包装专业知识，是一家专业生产成型杯盖机、暖宝宝包装机、艾灸贴包装机、护颈理疗贴包装机、四边封包装机，蒸汽眼罩包装机，的科技型企业。具有一定的技术力量和先进的生产工艺；有现代化的科学管理体系和完善的服务体系，拥有一支具有青春活力的精锐团队。

自公司成立以来，始终坚守“诚信为本，品质至上、服务至优、发展学习，创新”的企业精神。本着“科技以人为本，服务以客为尊”的发展理念，近年来公司现场实行6S管理，不断改善工作环境增强综合管理水平，不断营造良好的工作氛围构建文化核心价值体系，不断提升企业综合能力，秉着以诚为道，以优取胜来开拓市场，也愿意成为更多的企业可信赖的长期合作伙伴！

- 客户第一 Client First
- 正直诚信 Honesty
- 敬业担当 Dedication And Commitment
- 开放合作 Open Cooperation
- 持续成长 Continuous Growth



Honour and recognition

Laying solid footing

荣誉与认同 奠定坚实脚步



TECHNOLOGICAL INNOVATION

From national high-tech enterprises to provincial and municipal science and innovation benchmarks, each qualification is a deep recognition of the "precision manufacturing + medical grade quality control" dual-engine strategy, more than 30 invention patents to support the steam eye mask, moxibustion stickers and other health products of the whole process of encapsulation innovation in the field of global medical packaging to establish a Chinese technology discourse.

科技创新

从国家高新技术企业到省市科创标杆，每一份资质认证都是对“精密智造+医疗级品控”双引擎战略的深度认同。30多项发明专利支撑起蒸汽眼罩、艾灸贴等健康产品的全流程封装革新，在全球医疗包装领域树起中国技术话语权。

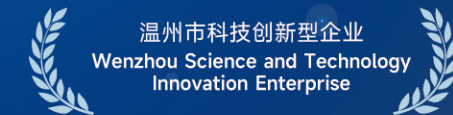

Steam Eye Mask Production Line

蒸汽眼罩生产线

Production Capacity
生产能力 **60-130**
Packages/minute

Overall Dimensions of Production Line
生产线外形尺寸
11000x800x1900mm



ZNB-330B

全自动智能高效暖包机

Automatic Intelligent And Efficient Warmer Pad Making Machine

YZ-220C

全自动蒸汽眼罩包装机

Automatic Steam Eye Mask Packaging Machine

LDJ-125

立式入袋机

Vertical Bagging Machine

Steam Eye Mask

Production Line

蒸汽眼罩生产线



PRODUCT APPLICATIONS

产品应用

Suitable for packaging activated carbon natural heating categories such as: warmer body pads, foot stickers, foot warmer pads, hand warmer pads, chest warmer pads, eye pads, knee pads, shoulder pads, neck pads, and so on, and other heterogeneous shape packaging.

适用于包装活性炭自然发热类如:

暖身贴、足贴、暖脚垫、暖手袋、暖胸贴, 眼贴, 护膝护肩护颈贴等等异形包装。

Global Excellent
Warm Pack Equipment Supplier
全球优秀暖包设备供应商

PART OF THE SAMPLE SHOW 部分样品展示



Main Technical Data 主要技术参数

ZNB-330B

Roll Cutting Times	滚切次数	15-40次/分 (pieces/minute)
Production Capacity	生产能力	180片/分(pieces/minute) (按双排一出六片每分钟30次计算)
Max.Pack size	最大包装尺寸	330X270mm
Automatic program	自动程序	全自动 (automatic)
Function	功能	充填、计量、其他 (filling, measurement, others)
Raw material	包装材料	无纺布、背胶纸复合材料 (non-woven fabric, stickers compound material)
Substance	物料类型	粉剂 (powder)
Total power	电源总功率	10.5Kw (380V)
Compressed air (Mpa)	压缩空气	0.6-0.8Mpa (>0.3 m³自备)
Overall dimension	外形尺寸	2970x700x1890mm (长x宽x高)
Weight	整机重量	1500Kg

PART OF THE SAMPLE SHOW 部分样品展示



Main Technical Data 主要技术参数

YZ-220C

Roll Cutting Times	滚切次数	15-120次/分 (times/minute)
Max material Width	材料最大宽度	230mm
Raw material	包装材料	无纺布针刺棉等, 最大卷材直径600mm, 卷轴孔径均为75mm (non-woven fabric, max diameter 600mm, inner size 75mm)
Compressed air (Mpa)	压缩空气	0.4-0.6Mpa
Power volage	电源电压	380V/220V 50HZ
Total power	总功率	约7Kw
Overall dimension	外形尺寸	3850×700×1850mm (长x宽x高)
Weight	整机重量	1200Kg

LDJ-125

Production capacity	生产能力	60-130袋/分钟(pieces/minute)
Bag width	包装袋宽度	110-120mm
Bag Length	包装袋长底	130-145mm
Total Power	电源总功率	6.5Kw (380V 50HZ)
Compressed Air(MPa)	压缩空气	0.6-0.8MPa
Dimension	外形尺寸	2100*880*1700mm
Weight	整机重量	900Kg

Fully automatic medium speed Heating Pad

Production Line

全自动中速暖宝宝生产线

Production Capacity
生产能力

210
Packages/minute

Overall Dimensions of Production Line
生产线外形尺寸
16000x1100x1800mm



ZNB-330B

全自动智能高效暖包机

Automatic Intelligent And Efficient Warmer Pad Making Machine

WFS-400

往复式四边封包装机

Reciprocating Four Side Seal Packaging Machine

Automatic Warmer Pad Production Line

全自动暖宝宝生产线



PRODUCT APPLICATIONS 产品应用

Suitable for packaging activated carbon natural heating categories such as: warmer body pads, foot stickers, foot warmer pads, hand warmer pads, chest warmer pads, eye pads, knee pads, shoulder pads, neck pads, and so on, and other heterogeneous shape packaging.

适用于包装活性炭自然发热类如：

暖身贴、足贴、暖脚垫、暖手袋、暖胸贴，眼贴，护膝护肩护颈贴等等异形包装。

Global Excellent
Warm Pack Equipment Supplier
全球优秀暖包设备供应商

PART OF THE SAMPLE SHOW 部分样品展示



Main Technical Data 主要技术参数

ZNB-330B

Roll Cutting Times	滚切次数	15-40次/分 (pieces/minute)
Production Capacity	生产能力	180片/分(pieces/minute) (按双排一出六片每分钟30次计算)
Max.Pack size	最大包装尺寸	330X270mm
Automatic program	自动程序	全自动 (automatic)
Function	功能	充填、计量、其他 (filling, measurement, others)
Raw material	包装材料	无纺布、背胶纸复合材料 (non-woven fabric, stickers compound material)
Substance	物料类型	粉剂 (powder)
Total power	电源总功率	10.5Kw (380V)
Compressed air (Mpa)	压缩空气	0.6-0.8Mpa (>0.3 m³自备)
Overall dimension	外形尺寸	2970x700x1890mm (长x宽x高)
Weight	整机重量	1500Kg

PART OF THE SAMPLE SHOW 部分样品展示



Main Technical Data 主要技术参数

WFS-400

Packaging Scope	包装范围	长 (50-280mm) X 宽 (50-200mm)
Packaging Speed	包装速度	20-80次/分 (按袋子规格与物料而定 depend by pouch size & material)
Production Capacity	生产能力	70X3=210包 (按1分钟70次1次3包计算)
Filling Dimensions	充填尺寸	在包装尺寸范围内按客户要求设计, 最大物料厚度15 mm
Width of Packaging Material	包材宽度	400-820mm
Outer Diameter of Material Roll	包材外径	420mm(最大)
Core Diameter of Material Roll	包材芯径	Φ75mm
Compatible Materials	适应包材	PET/AL/PE;PET/PE;NY/PE;NY/AL/PE;KOPP/PE
Power Supply	接入电源	AC380V 50Hz 最大60A (可按客户要求定制)
Compressed Air	压缩空气	0.4-0.6Mpa
Total Power	总功率	约17Kw
Overall Dimensions	外形尺寸	5300x1330x1650mm
Gross Weight	毛重	约 2300kg

Bag-In-Bag Packaging & Shoulder Neck Pad Integrated Production Line

包中包—肩颈贴生产线



Production Capacity
生产能力 **60-140**
Packages/minute

Overall Dimensions of Production Line
生产线外形尺寸
12000x1100x1900mm



BZB330

全自动包中包理疗包装机

Automatic Bag-in-Bag Physical Therapy Packaging Machine

HJT540

护颈理疗复合机

Neck Care Physical Therapy Compound Machine

Main Technical Data 主要技术参数

BZB-330

Roll Cutting Times	滚切次数	15-40次/分 (times/minute)
Max.Pack Size	最大包装尺寸	330X270mm
Automatic Program	自动程序	全自动 (fully automatic)
Function	功能	充填、计量、其他 (filling, measurement, others)
Raw Material	包装材料	无纺布、背胶纸复合材料、棉布 (non-woven fabric, stickers compound material, cotton)
Substance	物料类型	粉剂 (powder)
Total Power	电源总功率	约 (Around) 15Kw (380V)
Compressed Air (Mpa)	压缩空气	0.6-0.8Mpa (>0.3 m³自备Self provided)
Mold Cooling	模具冷却	60L/H, 自来水/循环水 (tap water or recycle water)
Overall Dimension	外形尺寸	4570×700×1750mm (长×宽×高) (L*W*H)
Weight	整机重量	2500Kg

HJT-540

Productivity	生产能力	60-140 pcs/min次/分
Max. Pack Size	最大包装尺寸	520*110mm
Automatic Program	自动程序	全自动Fully Automatic
Packing Material	包装材料	无纺布、针刺棉(non-woven fabric, acupuncture cotton)
Total Power	电源总功率	2.2Kw (380V) 胶机Glue machine: 6.5KW (380V)
Compressed Air(MPa)	压缩空气	0.4-0.6 MPa
Dimension	外形尺寸	3410*950*1850mm (长*宽*高) (L*W*H)
Weight	整机重量	1000Kg

Bag-In-Bag Packaging & Moxibustion Pad Integrated Production Line

包中包—艾灸贴生产线

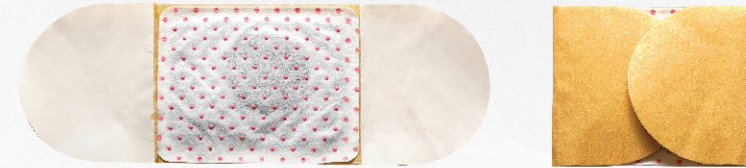

Production Capacity
生产能力 **60-120**
Packages/minute

Overall Dimensions of Production Line
生产线外形尺寸 **13500x1500x1900mm**



BZB-330GB

全自动包中包理疗包装机

Automatic Bag-in-Bag Physical Therapy Packaging Machine

HJT300

艾灸贴理疗复合机

Moxibustion Pad Physical Therapy Compound Machine

Main Technical Data 主要技术参数

BZB-330GB

Roll Cutting Times	滚切次数	15-40次/分 (pieces/minute)
Max.Pack Size	最大包装尺寸	330X270mm
Automatic Program	自动程序	全自动 (automatic)
Function	功能	充填、计量、其他 (filling, measurement, others)
Raw Material	包装材料	无纺布、背胶纸复合材料、棉布 (non-woven fabric, stickers compound material, cotton)
Substance	物料类型	粉剂 (powder)
Total Power	电源总功率	约15Kw (380V)
Compressed Air (Mpa)	压缩空气	0.6-0.8Mpa (>0.3 m³自备)
Mold Cooling	模具冷却	60L/H, 自来水/循环水 (tap water or recycle water)
Overall Dimension	外形尺寸	4450×700×1750mm (长×宽×高)
Weight	整机重量	2500Kg

HJT-300

Productivity	生产能力	60-120 PCS/min
Max. Pack Size	最大包装尺寸	300*200mm
Automatic Program	自动程序	全自动 Automatic
Packing Material	包装材料	无纺布、针刺棉
Total Power	电源总功率	2.2Kw (380V)、胶机 6.5KW (380V)
Compressed Air(MPa)	压缩空气	0.4-0.6 MPa
Dimension	外形尺寸	3600*1015*1960mm
Weight	整机重量	1250Kg

Automatic Warmer Pad Production Line

全自动暖宝宝生产线



Production Capacity
生产能力 **60-120**
Packages/minute

Overall Dimensions of Production Line
生产线外形尺寸 **12000x1500x1700mm**

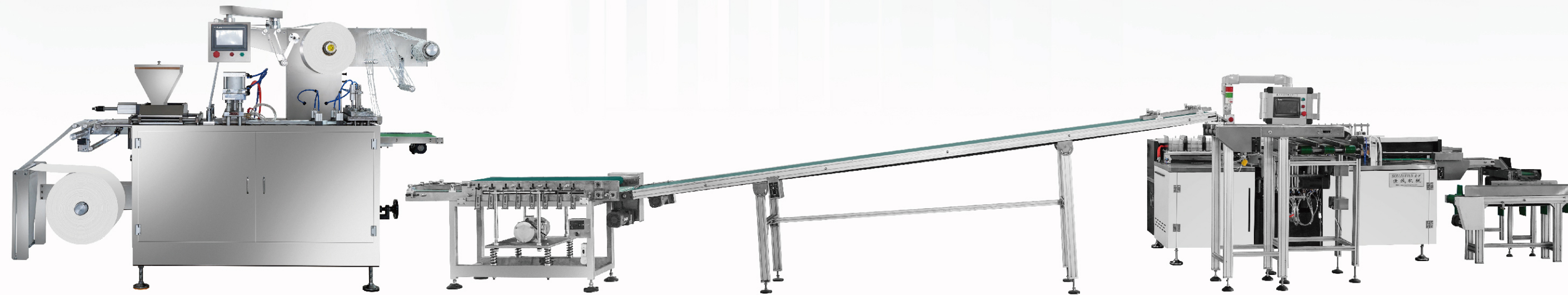

NB-330C2
全自动暖宝宝包装机
Automatic Warmer Pad Making Machine

TDJ-120
暖包套袋机
Warmer Pad Bagging Machine

Main Technical Data 主要技术参数

NB-330C2		
Productivity	生产能力	15-40 PCS/min
Max.pack.size	最大包装尺寸	330X180mm
Detree Of Automation	自动程序	全自动Automatic
Function	功能	充填、计量、其它 Filling,measurement,others
Packing Material	包装材料	无纺布、背胶纸复合材料
Substance	物料类型	粉剂Powder
Total Power	电源总功率	6.5Kw (380V)
Compressed Air(MPa)	压缩空气	0.6-0.8 MPa
Mold Cooling	模具冷却	60LH tap water/recycle water
Dimension	外形尺寸	2650*880*1650mm
Weight	整机重量	1000Kg

TDJ-120		
Packing speed	包装速度	60-120袋/分 (bags/min)
Bag Width	包装袋宽	115-130mm
Bag Length	包装袋长	145-180mm
Compressed air(Mpa)	压缩空气	0.6-0.8Mpa
Power voltage	电源电压	380V/50HZ
Total power	总功率	约6.4Kw
Overall dimension	外形尺寸	2500×1720×1430mm (长x宽x高)
Weight	整机重量	约900kg

Automatic Insole Production Line

全自动鞋垫生产线



Production Capacity
生产能力

60-120
Packages/minute

Overall Dimensions of Production Line
生产线外形尺寸

12000x1500x1700mm

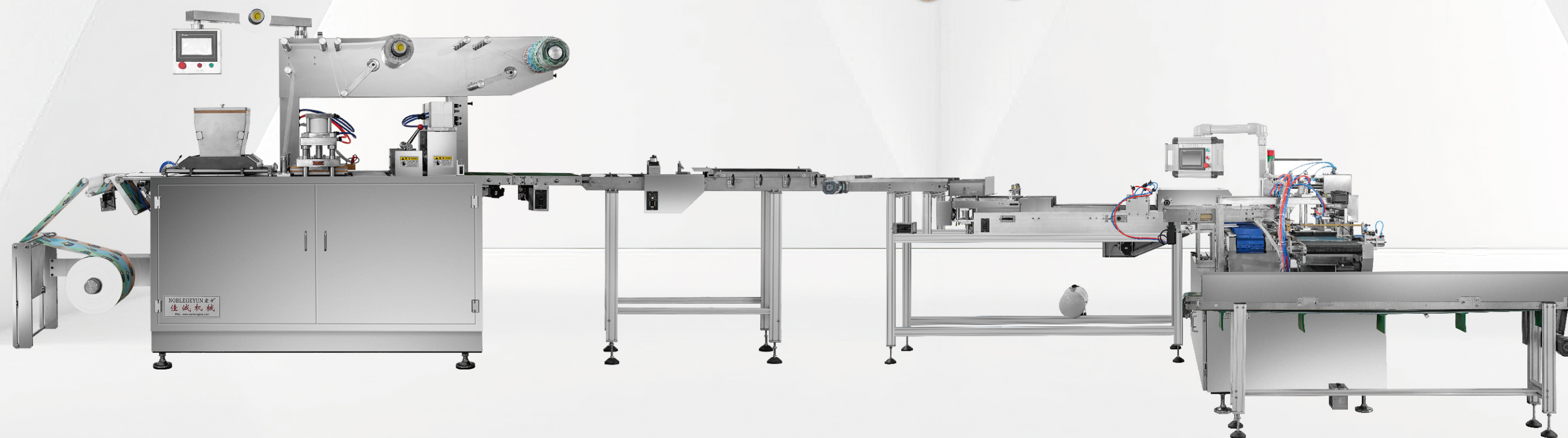

ZNB-330

全自动智能高效暖包机

Automatic Intelligent And Efficient Warmer Pad Making Machine

XDJ-80

鞋垫套袋机

Insole bagging machine

Main Technical Data 主要技术参数

ZNB-330

Roll Cutting Times	滚切次数	15-40次/分 (times/minute)
Production Capacity	生产能力	180片/分(pieces/minute) (按双排一出六片每分钟30次计算)
Max.Pack size	最大包装尺寸	330X270mm
Automatic program	自动程序	全自动 (automatic)
Function	功能	充填、计量、其他 (filling, measurement, others)
Raw material	包装材料	无纺布、背胶纸复合材料 (non-woven fabric, stickers compound material)

Substance	物料类型	粉剂 (powder)
Total power	电源总功率	10.5Kw (380V)
Compressed air (Mpa)	压缩空气	0.6-0.8Mpa (>0.3 m³自备)
Overall dimension	外形尺寸	2970×700×1890mm (长×宽×高)
Weight	整机重量	1500Kg

XDJ-80

Packing speed	包装速度	60-120 袋/分(bags/minute)
Bag Width	包装袋宽	95-110mm
Bag Length	包装袋长	250-300mm
Compressed air(Mpa)	压缩空气	0.6-0.8Mpa
Power voltage	电源电压	380 V/50HZ
Total power	总功率	约8.5Kw
Overall dimension	外形尺寸	2470X3870x1580mm (长×宽×高)
Weight	整机重量	约 1000kg

Hand and Foot Pad Production Line

手足生产线



Production Capacity
生产能力 **60-125**
Packages/minute

Overall Dimensions of Production Line
生产线外形尺寸 **11000x800x2000mm**

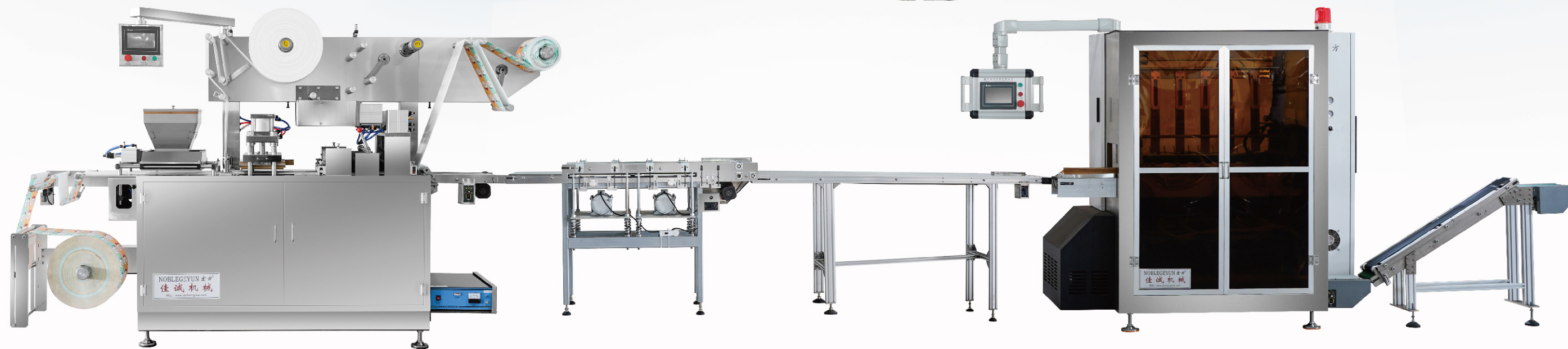

BZB-330

手足生产自动线

Automatic Line For Hand And Foot Production

LDJ-125

立式入袋机

Vertical Bagging Machine

Main Technical Data 主要技术参数

BZB-330

Roll Cutting Times	滚切次数	15-40次/分 (pieces/minute)
Max.Pack Size	最大包装尺寸	330X270mm
Automatic Program	自动程序	全自动 (automatic)
Function	功能	充填、计量、其他 (filling, measurement, others)
Raw Material	包装材料	无纺布、背胶纸复合材料、棉布 (non-woven fabric, stickers compound material, cotton)
Substance	物料类型	粉剂 (powder)
Total Power	电源总功率	约15Kw (380V)
Compressed Air (Mpa)	压缩空气	0.6-0.8Mpa (>0.3 m³自备)
Mold Cooling	模具冷却	60L/H, 自来水/循环水 (tap water or recycle water)
Overall Dimension	外形尺寸	4450×700×1750mm (长×宽×高)
Weight	整机重量	2500Kg

LDJ-125

Production capacity	生产能力	60-125 袋/分(Bag/minute)
Bag width	包装袋宽度	110-120mm
Bag Length	包装袋长底	130-145mm
Total Power	电源总功率	6.5Kw (380V 50HZ)
Compressed Air(MPa)	压缩空气	0.6-0.8MPa
Dimension	外形尺寸	2100*880*1700mm
Weight	整机重量	900Kg

WFS-400

Reciprocating Plaster Patch Four Side Seal Packaging Machine

往复式膏药贴四边封

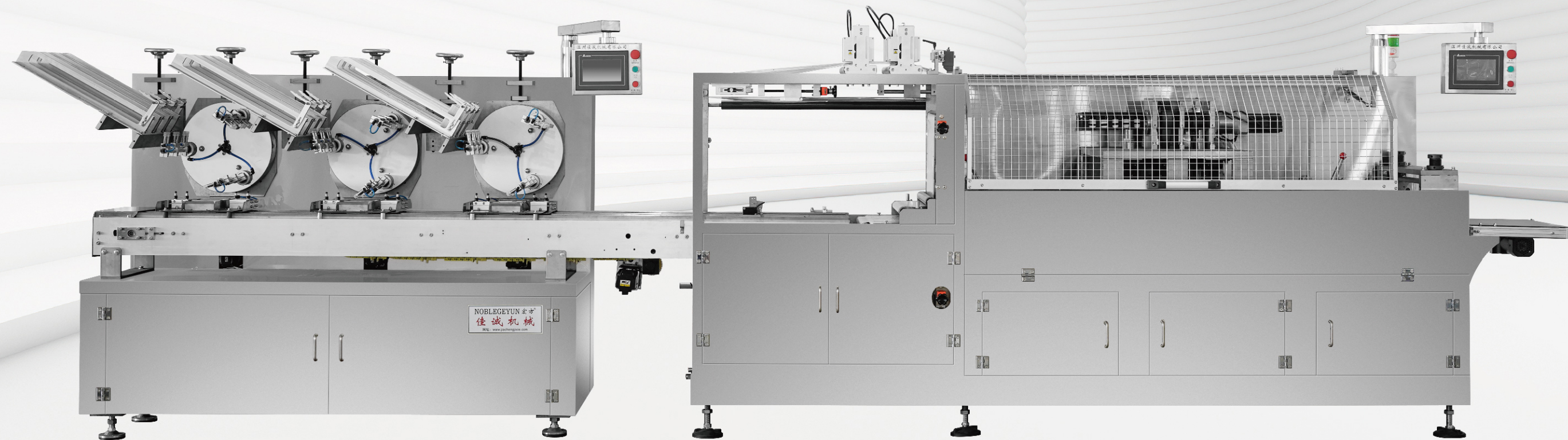

Production Capacity
生产能力

60-210
Packages/minute

Overall Dimensions of Production Line
生产线外形尺寸

9000x1000x1700mm

PRODUCT APPLICATIONS 产品应用

Suitable for medicine, daily chemicals, foodstuffs such as:
Warmer pads, eye pads, plaster patch, medical gauze, etc.

适用于医药、日化、食品类如：
暖贴、眼贴、膏药贴、医用纱布等。

Main Technical Data 主要技术参数

WFS-400		
Packaging Scope	包装范围	长 (50-280mm) X 宽 (50-200mm)
Packaging Speed	包装速度	20-80次/分 (按袋子规格与物料而定 depend by pouch size & material)
Production Capacity	生产能力	70X3=210包 (按1分钟70次1次3包计算)
Filling Dimensions	充填尺寸	在包装尺寸范围内按客户要求设计, 最大物料厚度15 mm
Width of Packaging Material	包材宽度	400-820mm
Outer Diameter of Material Roll	包材外径	420mm(最大)
Core Diameter of Material Roll	包材芯径	Φ75mm
Compatible Materials	适应包材	PET/AL/PE;PET/PE;NY/PE;NY/AL/PE;KOPP/PE
Power Supply	接入电源	AC380V 50Hz 最大60A (可按客户要求定制)
Compressed Air	压缩空气	0.4-0.6Mpa
Total Power	总功率	约17Kw
Overall Dimensions	外形尺寸	5300×1330×1650mm
Gross Weight	毛重	约 2300kg

BZB-330GB3

Automatic Bag-In-Bag Waist Pad Physical Therapy Packaging Machine

全自动包中包腰贴理疗一体机



Main Technical Data 主要技术参数

BZB-330GB3

Roll Cutting Times	滚切次数	10-35 贴/分 (pieces/minute)
Max.Pack size	最大包装尺寸	350*160mm
Automatic program	自动程序	全自动 (automatic)
Function	功能	充填、计量、其他 (filling, measurement, others)
Raw material	包装材料	无纺布、背胶纸复合材料、棉布 (non-woven fabric, stickers compound material, cotton)
Substance	物料类型	粉剂 (powder)
Total power	电源总功率	约 24Kw (380V)
Compressed air (Mpa)	压缩空气	0.6-0.8Mpa (>0.3 m³自备)
Mold cooling	模具冷却	60L/H, 自来水/循环水 (tap water or recycle water)
Overall dimension	外形尺寸	5050x720x2200mm (长 x 宽 x 高)
Weight	整机重量	3200Kg

PRODUCT APPLICATIONS 产品应用

Suitable for packing activated carbon natural heat with herbal powder hot moxibustion paste such as:
Neck, Shoulder, knee, abdomen and other body points of the hot moxibustion paste packaging.

适用于包装活性炭自然发热与草药粉剂热灸贴如：
颈部、肩部、膝部、腹部等身体的各穴位的热灸贴包装。

Production Capacity
生产能力

10-35
Pieces/minute

Overall Dimensions of Production Line
生产线外形尺寸

5000x800x2000mm

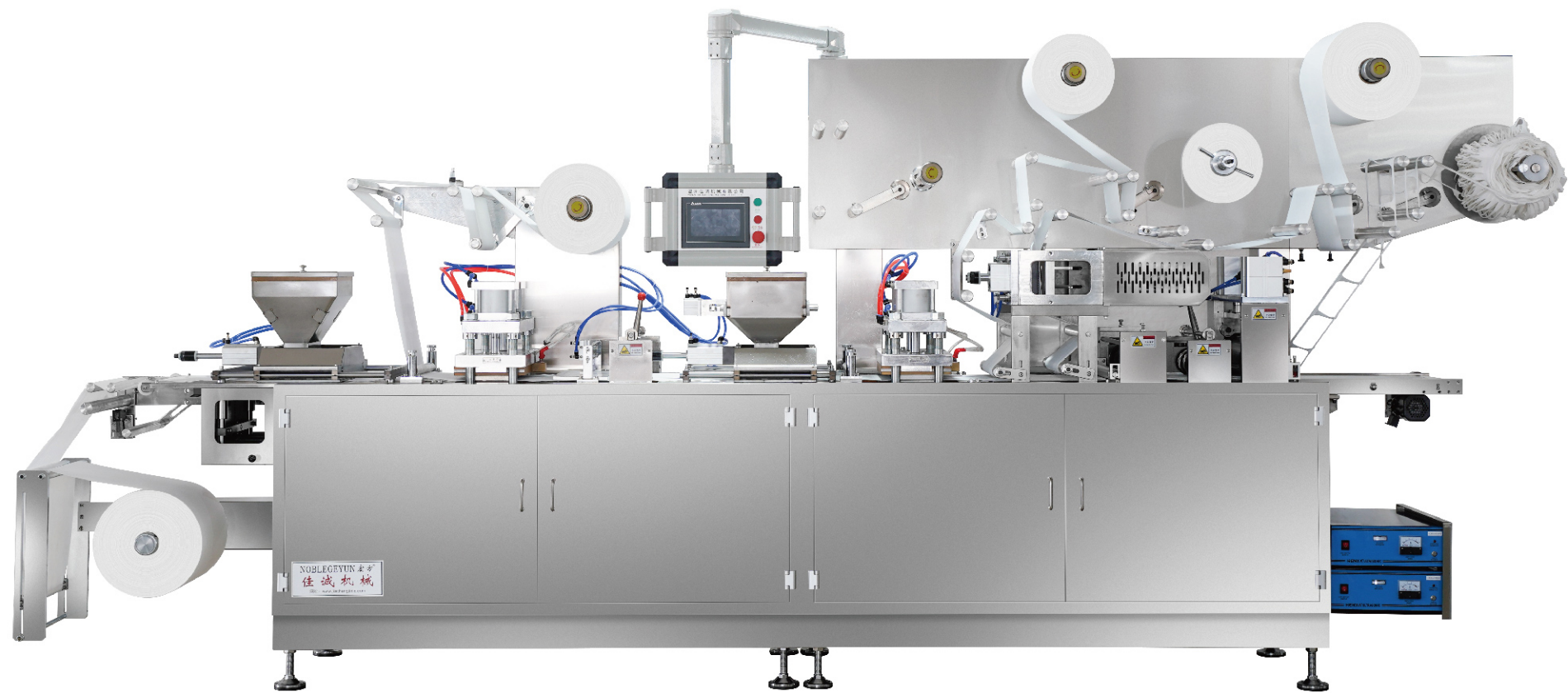

BZB-330GB2

Automatic Bag-In-Bag Knee Pad Physical Therapy Packaging Machine

全自动包中包护膝理疗一体机

Production Capacity
生产能力 **10-35**
Pieces/minute

Overall Dimensions of Production Line
生产线外形尺寸 **5000x800x2000mm**

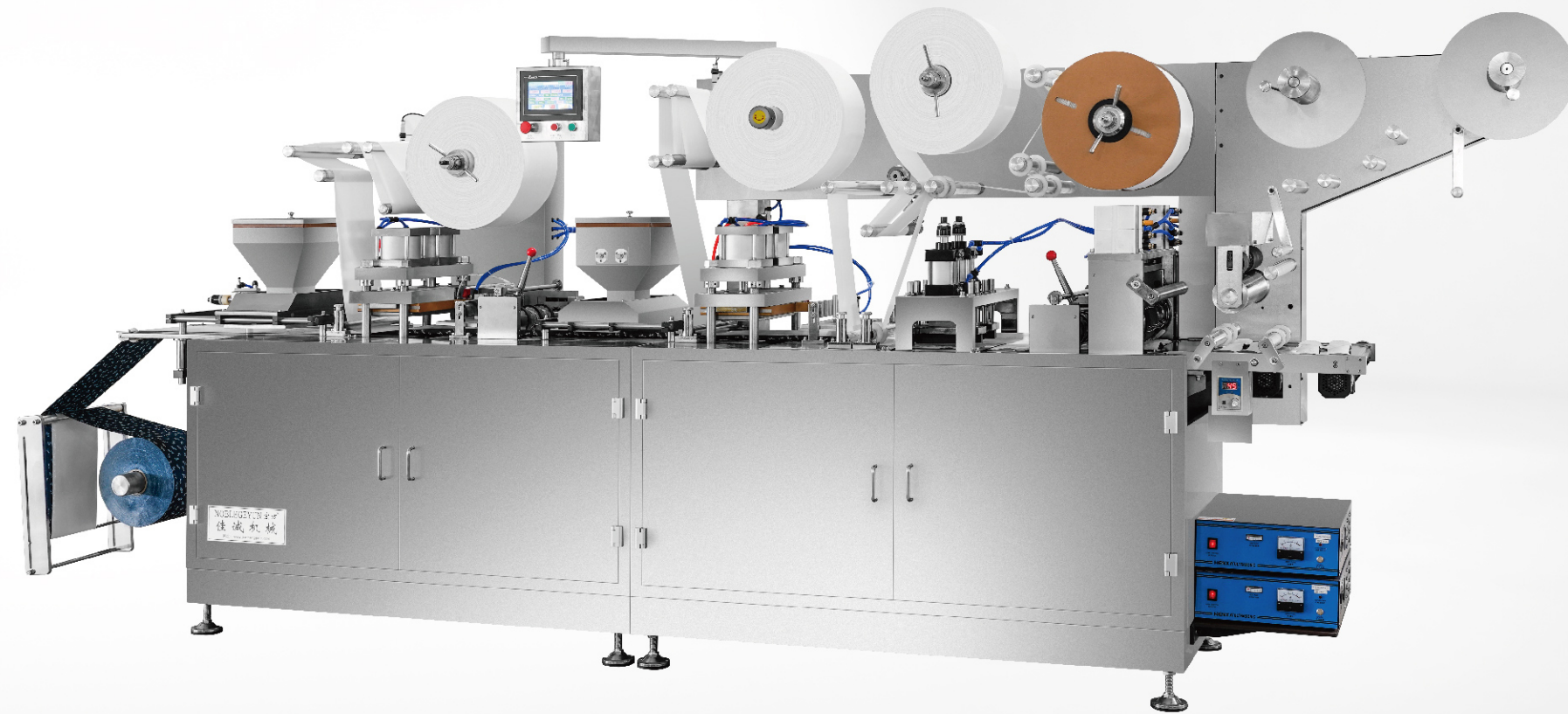

PRODUCT APPLICATIONS 产品应用

Suitable for packing activated carbon natural heat with herbal powder hot moxibustion paste such as:

Neck, Shoulder, knee, abdomen and other body points of the hot moxibustion paste packaging.

适用于包装活性炭自然发热与草药粉剂热灸贴如：颈部、肩部、膝部、腹部等身体的各穴位的热灸贴包装。

Main Technical Data 主要技术参数

BZB-330GB2

Roll Cutting Times	滚切次数	10-35贴/分 (pieces/minute)
Max.Pack size	最大包装尺寸	330X270mm
Automatic program	自动程序	全自动 (automatic)
Function	功能	充填、计量、其他 (filling, measurement, others)
Raw material	包装材料	无纺布、背胶纸复合材料、棉布 (non-woven fabric, stickers compound material, cotton)
Substance	物料类型	粉剂 (powder)
Total power	电源总功率	约24Kw (380V)
Compressed air (Mpa)	压缩空气	0.6-0.8Mpa (>0.3 m³自备)
Mold cooling	模具冷却	60L/H, 自来水/循环水 (tap water or recycle water)
Overall dimension	外形尺寸	5050x870x1925mm (长x宽x高)
Weight	整机重量	3200Kg

YZ-220C

Automatic High Speed Steam Eye Mask Packaging Machine

全自动高速蒸汽眼罩包装机



Main Technical Data 主要技术参数

YZ-220C

Roll Cutting Times	滚切次数	15-120次/分 (pieces/minute)
Max material Width	材料最大宽度	230mm
Raw material	包装材料	无纺布针刺棉等, 最大卷材直径600mm, 卷轴孔径均为75mm (non-woven fabric, max diametet 600mm, inner size 75mm)
Compressed air (Mpa)	压缩空气	0.4-0.6Mpa
Power volage	电源电压	380V/220V 50HZ
Total power	总功率	约7Kw
Overall dimension	外形尺寸	3850×700×1850mm (长x宽x高)
Weight	整机重量	1200Kg

Production Capacity
生产能力

15-120
Pieces/minute

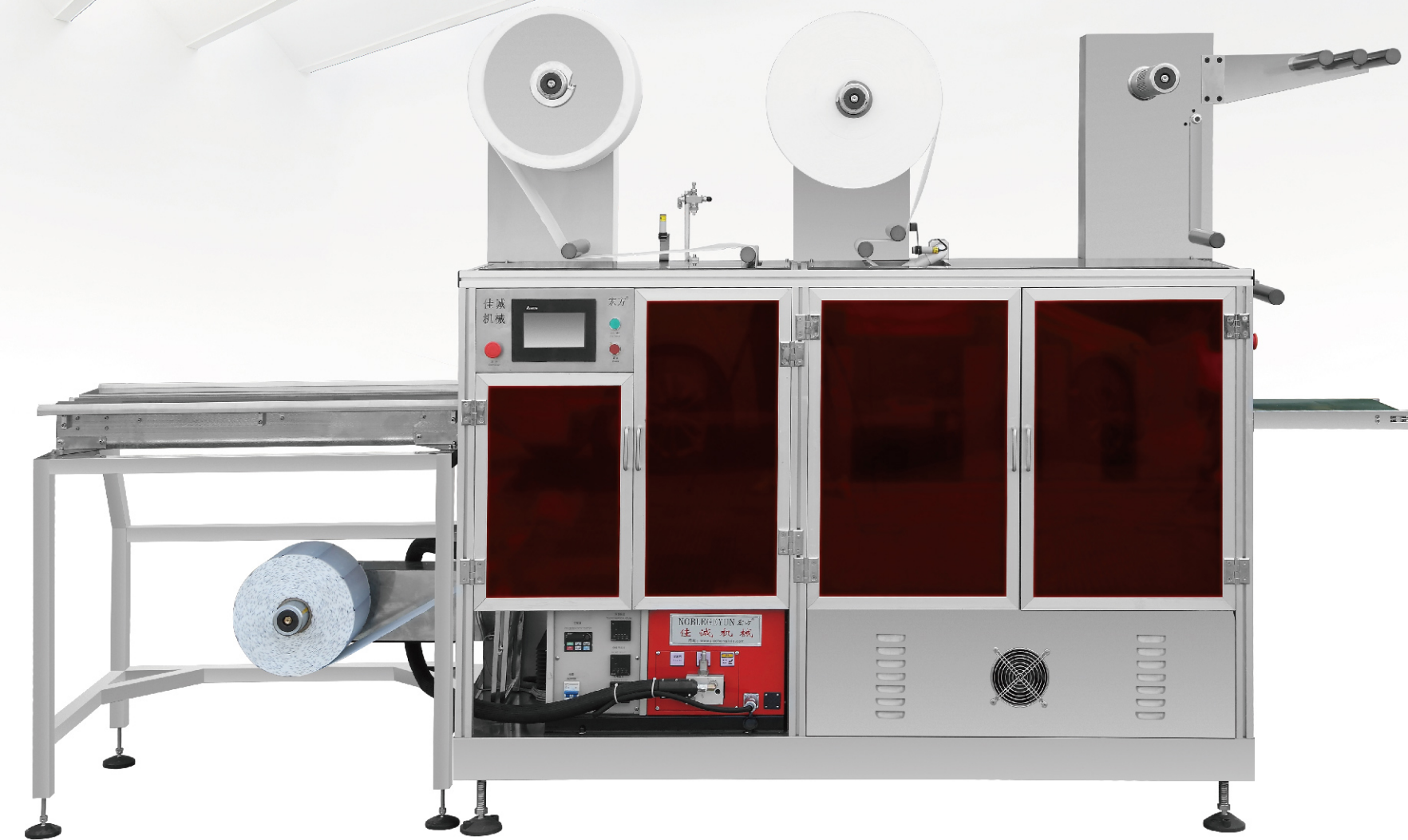

WF-330

Horizontal Powder Packaging Machine

卧式粉剂包装机



Production Capacity
生产能力

15-40

PCS/min



PRODUCT APPLICATIONS 产品应用

It applies to pack powder herb pad, active carbon heating mini pad and so on.

适用于包装粉状中草药类贴剂、活性炭发热类迷你小贴剂等。

Main Technical Data 主要技术参数

WF-330

Productivity	生产能力	15-40 PCS/min
Max.pack.size	最大包装尺寸	330X160mm
Detree Of Automation	自动程序	全自动Automatic
Function	功能	充填、计量、其它 Filling,measurement,others
Packing Material	包装材料	无纺布、纸复合材料 Non-woven fabric, stickers compound material
Substance	物料类型	粉剂Powder
Total Power	电源总功率	6.5Kw (380V)
Compressed Air(MPa)	压缩空气	0.6-0.8 MPa
Mold Cooling	模具冷却	60LH tap water/recycle water
Dimension	外形尺寸	2730*880*1650mm
Weight	整机重量	1000Kg

WFS-400

Reciprocating Four Side Seal Packaging Machine

往复式四边封包装机

PRODUCT APPLICATIONS 产品应用

Suitable for medicine, daily chemicals, foodstuffs such as:
Warm sticker, eye sticker, plaster sticker, medical gauze, etc.

适用于医药、日化、食品类如：
暖贴、眼贴、膏药贴、医用纱布等。

Main Technical Data 主要技术参数

WFS-400

Packaging range	包装范围	长 (50-280mm) X 宽 (50-200mm)
Packaging speed	包装速度	20-80次/分 (按袋子规格与物料而定 depend by pouch size & material)
Production capacity	生产能力	70X3=210包 (按1分钟70次1次3包计算)
Filling size	充填尺寸	在包装尺寸范围内按客户要求设计, 最大物料厚度15 mm
Package width	包材宽度	400-820mm
Package outer diameter	包材外径	420mm(最大)
Package core diameter	包材芯径	φ75mm
Adaptation of package material	适应包材	PET/AL/PE;PET/PE;NY/PE;NY/AL/PE;KOPP/PE
Power supply	接入电源	AC380V 50Hz 最大60A (可按客户要求定制)
Compressed air	压缩空气	0.4-0.6Mpa
Total power	总功率	约17Kw
Overall Dimension	外形尺寸	5300×1330×1650mm
Gross weight	毛重	约 2300kg



Production Capacity
生产能力

60-180
PCS/min